



# Johns Manville

### Fiber Glass Duct Board

#### Fabrication Instructions

- SuperDuct® RC Duct Board
- Mat-Faced Micro-Aire® Duct Board
- Micro-Aire® Type LP Duct Board

#### Introduction

The following instructions detail hand fabrication of a one-piece straight duct from a 48" x 120" x 1" thick (1.22 m x 3.05 m x 25 mm) sheet of SuperDuct RC, Mat-Faced Micro-Aire or Micro-Aire Type LP duct board where the total of the inside duct dimensions equals 112" (2.84 m) or less.

Instructions for other thicknesses and for fabricating and joining other components, such as two-piece straight ducts, elbows, take-offs and transitions for complete fiber glass duct board systems, are detailed and illustrated in the current NAIMA Fibrous Glass Duct Construction Standards ([www.naima.org](http://www.naima.org)). This fabrication instruction sheet is not meant to be a duct-system fabrication manual.

#### Measurement for Centerline Method

Layout is done on the fiber glass duct boards before fabrication is started, with measurements keyed to the corner folds. In all cases, the INSIDE dimension (I.D.) of the duct is the determining factor. The cross-section drawing to the right of a folded fiber glass duct board shows how the fabrication allowances are added to the basic I.D. duct dimensions.

Grooving tools, designed for making proper and accurate cuts in these

fiber glass duct boards, are available from Johns Manville Air Handling distributors. Use of the shiplap grooving method is recommended to allow conformance to the practice of Modular Duct Construction.

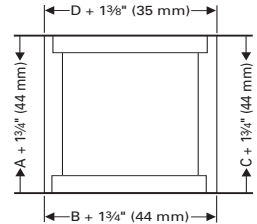

This drawing illustrates the measuring and shiplap grooving steps on the flat board.

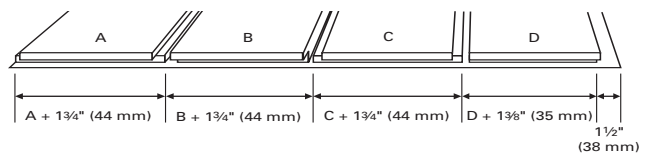

#### Fabrication Instructions

1. Begin at the left edge of the board and mark, near top and bottom edges of the wool side, in this order:

- Centerline for groove AB (first panel)
- Centerline for groove BC (second panel)
- Centerline for groove CD (third panel)
- Line at start of stapling flap
- Cutoff line at right end of duct blank

2. On the left edge of the board (opposite end of board that has stapling flap), cut the closure joint rabbet with a female tool, such as the Amcraft Gray Tool.

3. Use a shiplap tool, such as the Amcraft Orange Tool, to cut the grooves on the first three centerlines for the corner folds. When using the Orange Tool, be sure to first make a right-hand shiplap groove, then a left-hand groove, then another right-hand groove.

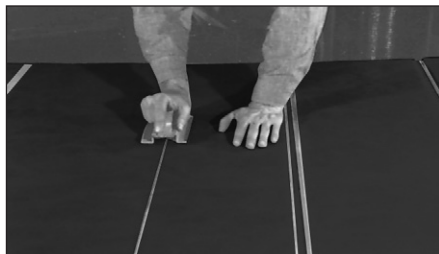

4. Prepare the stapling flap by stripping the fiber glass insulation from the facing. In making the perpendicular knife cut through the insulation, 1 1/2" (38 mm) from the edge of the board; use care not to cut the facing.

5. Fold the completed duct blank to form the duct section. Be sure that the shiplap corners fold at the centerline point as shown here, or the corner will not form correctly. Also, be sure to properly seat the flush edge in the rabbet cut at the closure joint.

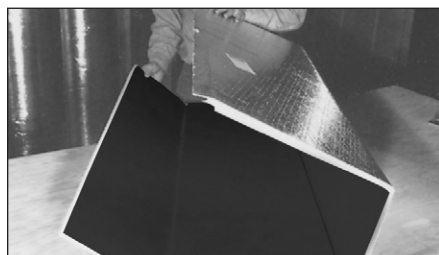

6. While holding the duct canted over at about 30° beyond square, staple the longitudinal flap approximately 2" (51 mm) on centers. Fasten flap with outward clinch staples placed about 1/2" (13 mm) in from edge of facing. Starting at the center of the duct, and with flap pulled smooth and taut, staple on approximately 2" (51 mm) centers out to each end.

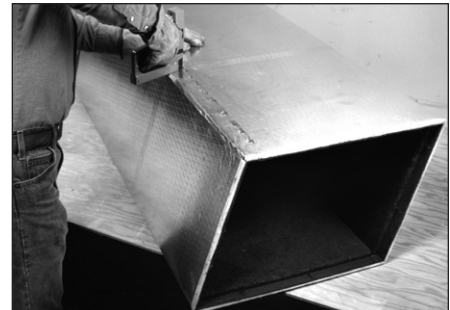

7. Secure the joint with a UL 181A listed closure system as described on the back of these instructions.



8. Connect the sections, making sure the male and female slip-joint ends are firmly seated. Smooth the stapling flap over the adjoining section and staple on approximately 2" (51 mm) centers.



Use the I, II or IV Closure Systems listed on the back to complete the connection.

# Fiber Glass Duct Board

## Fabrication Instructions

### • SuperDuct® RC Duct Board • Mat-Faced Micro-Aire® Duct Board • Micro-Aire® Type LP Duct Board

#### Closure Systems

In order to meet the requirements of UL 181 for a Class 1 Air Duct System, closures meeting the requirements of UL 181A must be used with SuperDuct RC, Mat-Faced Micro-Aire or Micro-Aire Type LP duct board.

#### Closure I

##### UL 181A-H Closures

Use tapes listed and labeled in accordance with Standard UL 181A and marked "181A-H". Tapes in compliance with this standard must be imprinted with this information. Heat seal all longitudinal and circumferential joints according to tape manufacturers' recommendations. Center strip over edge of stapling flap. Staples are not required when automatic closure equipment is used for the longitudinal joint.

#### Closure II

##### UL 181A-P Pressure Sensitive Tapes

Use tapes listed and labeled in accordance with Standard UL 181A and marked "181A-P". Tapes in compliance with this standard must be imprinted with this information.

Use tape that is a minimum 1" (25 mm) wider than the thickness of the board. Apply to all longitudinal and circumferential joints and rub in carefully using a squeegee or similar tool. The tape should be rubbed in until the scrim pattern from the duct board facing shows through the tape. Center tape over the edge of stapling flap. Heat seal if temperature is below 40°F (4°C).

#### Closure IV

##### UL 181A-M Mastic Closure

Use mastics listed and labeled in accordance with Standard UL 181A and marked "181A-M". Before applying, stir the mastic thoroughly. Brush on a 4" (102 mm) wide coating over the stapled flap. Embed the open mesh glass tape in the mastic. **Apply an additional coat of mastic over the tape, filling in the mesh.**

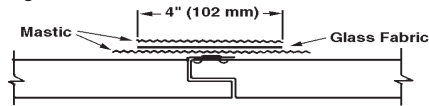

#### Limitation of Liability

If the closure system is not one of the approved systems noted above, and if application is not in accordance with stated procedures, the UL 181 Class 1 air duct rating, and the Johns Manville product warranty are void.

#### Fire-Rated Assemblies

Mat-Faced Micro-Aire, SuperDuct RC or Micro-Aire Type LP duct board 1" (25 mm) thick is accepted in lieu of sheet metal duct in many fire-rated assemblies. See UL Label for design numbers.

• **Fabrication.** All fabrication and joint stapling shall be as described in these instructions, or as described in the current NAIMA Fibrous Glass Duct Construction Standards.

• **Joint Treatment.** Use only the Closure IV mastic and glass fabric joint treatment applied in accordance with application instructions on mastic container. This closure method must be used on both sleeve equipment joints.

#### Bottom Diffuser Connector

A 22-gauge (0.8 mm) galvanized sheet metal liner (1), 24" (610 mm) long by the inside dimensions of the duct (3), with hole cut in the center equal in diameter to (2) is prepared. The round sheet metal duct of equal gauge (2) with 1" (25 mm) dovetail or tabs is inserted through the hole and secured with dovetail tabs. Cut a hole into the center bottom of the fiber glass duct (3) equal in diameter to the round sheet metal duct (2). Cut the fiber glass duct (3) circumferentially through the centerline of this hole. The diffuser (5) is attached directly to the sheet metal duct with sheet metal screws. Slide metal assembly of (1) and (2) into the split joint of the fiber glass duct (3). The assembly must be supported by the two hangers (4) directly under the sheet metal liner with one hanger on each side of the finished assembly.

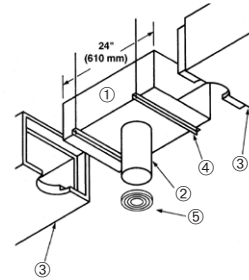

- 1 Sheet steel duct liner (22 MSG [0.8 mm]) with sheet steel throat
- 2 Sheet metal round drop duct
- 3 Class 1 air ducts
- 4 16 MSG (1.5 mm) cold rolled steel, 1½" (38 mm) deep suspended by 12 SWG (2.6 mm) galvanized steel hanger wire
- 5 Diffuser

Method of joining section of air duct to sheet metal take-off on insulated metal or fibrous glass plenum:

#### Top or Side View

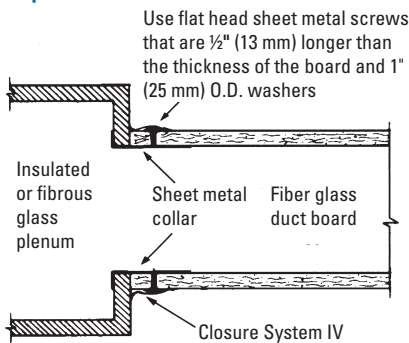

#### End View

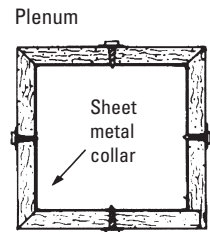

Do not connect to metal. If duct system is to be used for summer air conditioning only, all diffusers and return air grilles must be positively sealed during winter to prevent the entry of moisture.

## North American Sales Offices, Insulation Systems



717 17th St.  
Denver, CO 80202  
(800) 654-3103  
specJM.com

**Eastern Region**  
P.O. Box 158  
Defiance, OH 43512  
(800) 334-2399  
Fax: (419) 784-7866

**Western Region & Canada**  
P.O. Box 5108  
Denver, CO 80217  
(800) 368-4431  
Fax: (303) 978-4661

The physical and chemical properties of the Fiber Glass Duct Boards represent typical, average values obtained in accordance with accepted test methods and are subject to normal manufacturing variations. They are supplied as a technical service and are subject to change without notice. Numerical flame spread and smoke developed ratings are not intended to reflect hazards presented by these or any other materials under actual fire conditions. Check with the Regional Sales Office nearest you to ensure current information. **All Johns Manville products are sold subject to Johns Manville's standard Terms and Conditions including Limited Warranty and Limitation of Remedy. For a copy of the Johns Manville standard Terms and Conditions, Limited Warranty and Limitation of Remedy, and information on other Johns Manville thermal insulations and systems, call (800) 654-3103.**