

FS 5800
EXPANSION JOINT -EJ- FIRE BARRIER*
 Installation Instructions

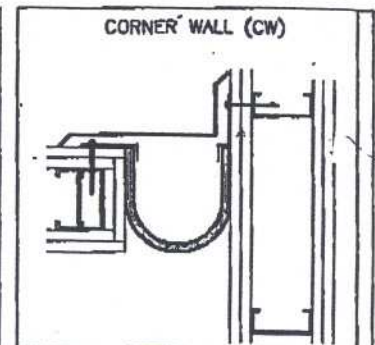
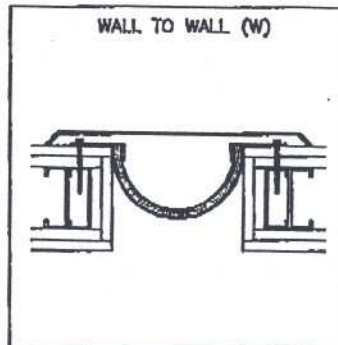
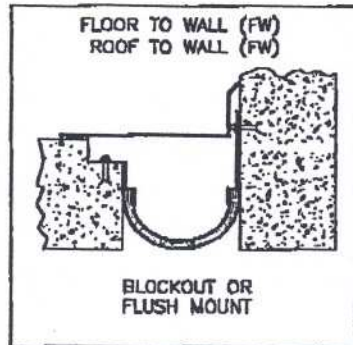
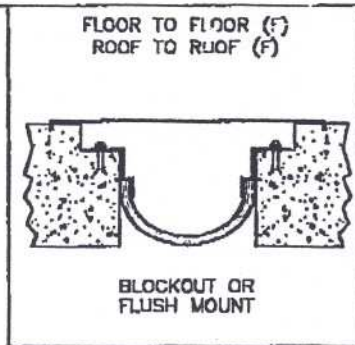

Horizontal:
 FS 5800-F1
 FS 5800-F2
 FS 5800-F3
 FS 5800-F4
 FS 5800-F5
 FS 5800-F6

Horizontal:
 FS 5800-FW1
 FS 5800-FW2
 FS 5800-FW3
 FS 5800-FW4
 FS 5800-FW5
 FS 5800-FW6

Vertical:
 FS 5800-W1
 FS 5800-W2
 FS 5800-W3
 FS 5800-W4
 FS 5800-W5
 FS 5800-W6

Vertical:
 FS 5800-CW1
 FS 5800-CW2
 FS 5800-CW3
 FS 5800-CW4
 FS 5800-CW5
 FS 5800-CW6

General Instructions:

- Fire Barriers must be installed in accordance with installation instructions to maintain UL® Rating.
- These instructions are for all horizontal and vertical FS5800 installations for 1"~6" nominal joint widths.
- If splicing is required, see the separate splicing instructions.
- The galvanized flanges are always required for installation.
- Appropriate fasteners supplied by others are required for all the horizontal and vertical installations.
- Typically, the same fasteners can be used to fasten the cover plate mechanism and the fire barriers.
- Wear heavy duty work gloves and eye protection during the entire installation process.

Packaging:

Each carton contains one 25 foot roll of FS5800 EJ Fire Barrier, one kit with the necessary material for splicing, the installation instructions and the splicing instructions. The galvanized flanges necessary for installation are packaged separately.

Material Preparation:

Roll out product face up (the side with the UL® label) and cut to length. The insulation portion of the product can be formed into a "U" or "V" shape to help it fit into the expansion joint this can be done by crimping the insulation along the center line with a pipe or board. (See Fig. A)

Fig. A
 Material Preparation

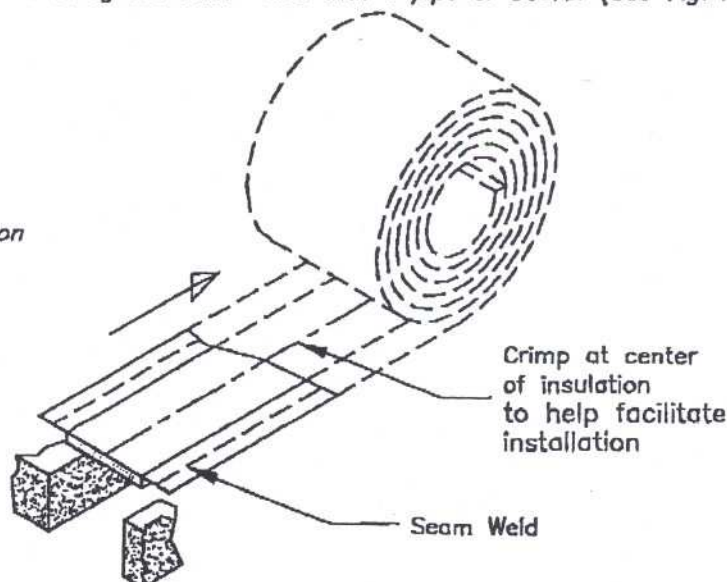

* Patent Pending

Installation Instructions
Floor to Wall
Roof to Wall

Step 1

After completing material preparation described on page 1 and as shown in Fig. A, place the fire barrier in the expansion joint. The foil flanges can be folded along the seam weld line onto the exposed face of the floor slab. The foil flange can be run up the wall on the other side of the joint. (See Fig. B2). With the Low Profile (LP) galvanized flange configuration on the wall side, the foil flange can be folded over itself before the galvanized flange is fastened into place. (See Fig. C2)

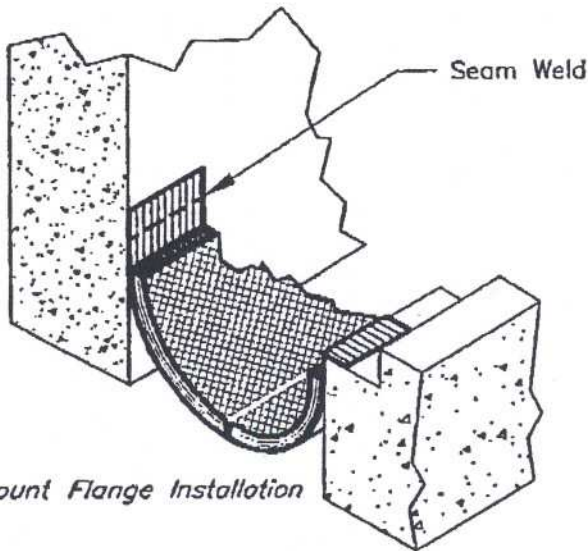

Fig. B2
 Surface Mount Flange Installation

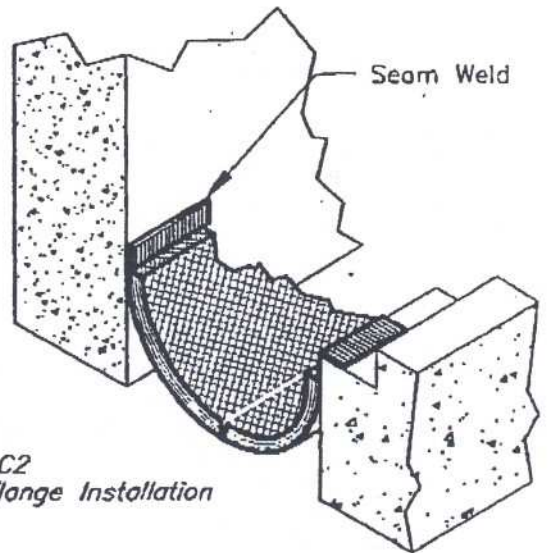

Fig. C2
 LP Flange Installation

Step 2

Cut the galvanized flanges to length and drill appropriate size holes with maximum spacing of 18". Install the flanges with appropriate fasteners (by others) as shown. (See Figs. D2 & E2)

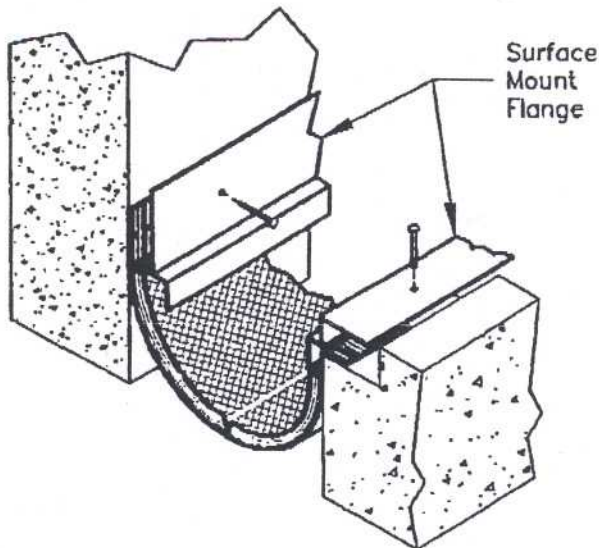

Fig. D2
 Surface Mount Flange Installation

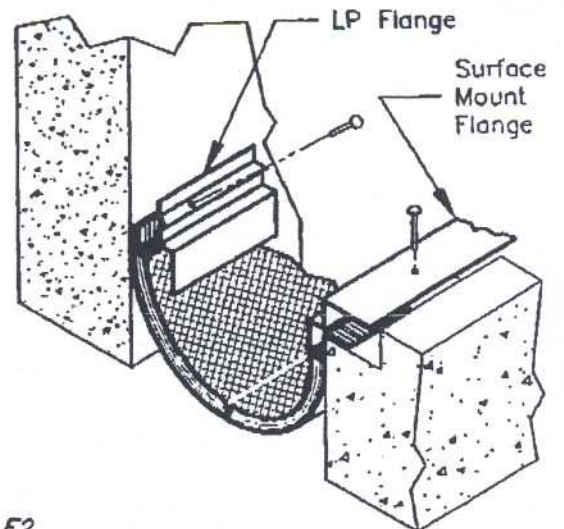

Fig. E2
 LP Flange Installation

Step 3

Install the expansion joint covers (by others) over the joint or in the blockout with appropriate fasteners (by others).

Installation Instructions
Horizontal or Floor and Roof Joints

Step 1
 After completing material preparation described on page 1 and as shown in Fig. A, place the fire barrier in the expansion joint. The foil flanges can be folded along the seam weld line onto the exposed face of the concrete slab. (See Fig. B). With the Low Profile (LP) galvanized flange, the foil flanges can be folded along the seam weld line down inside the expansion joint void so that no part of the barrier is on the exposed surface of the floor. (See Fig. C)

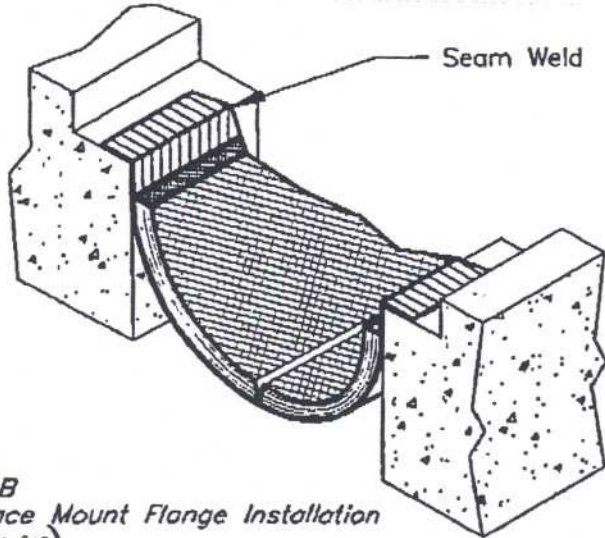

Fig. B
 Surface Mount Flange Installation
 (FLUSH)

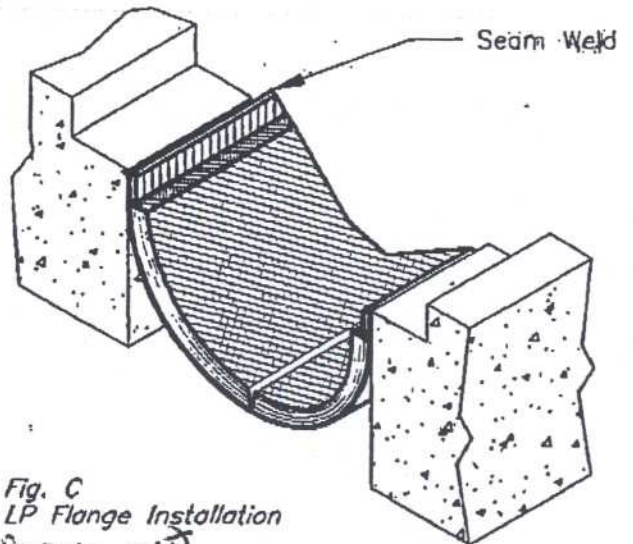

Fig. C
 LP Flange Installation
 (BLOCK OUT)

Step 2
 Cut the galvanized flanges to length and drill appropriate size holes with maximum spacing of 18". Install the flanges with appropriate fasteners (by others) as shown. (See Figs. D & E)

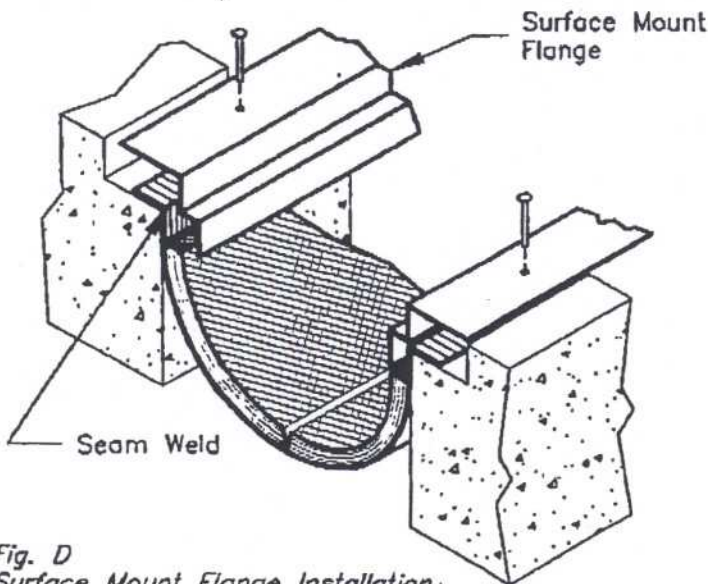

Fig. D
 Surface Mount Flange Installation

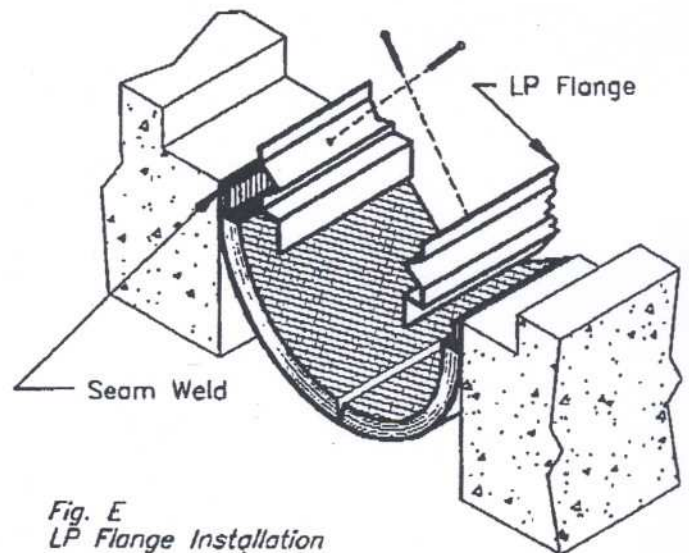

Fig. E
 LP Flange Installation

Step 3
 Install the expansion joint covers (by others) over the joint or in the blockout with appropriate fasteners (by others).

FS 5800
EXPANSION JOINT -EJ- FIRE BARRIER*
Splicing Instructions

In some cases it will be necessary to make longer sections of expansion joint blankets out of smaller pieces. In these cases the following instructions are to be used to splice two or more pieces together. It is highly recommended that this procedure be performed prior to installation in the wall or floor, as this procedure is much less time consuming when performed on a flat surface. After the splicing is completed, the installation procedure remains the same as described in the installation instructions.

Note: Fire Barriers must be spliced in accordance with splicing instructions to maintain UL® Rating.

Step 1

Lay each blanket segment on a flat surface. Measure out 12" from the ends of each blanket to be spliced. Draw a line directly across each package at the 12" mark. This will be the splice zone. Remove all of the tie pins from within the splice zone of each blanket. (See Figs. 1 & 2)

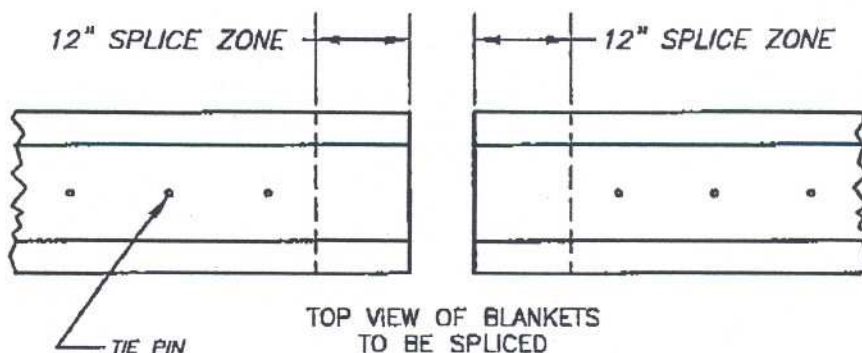

Fig. 1

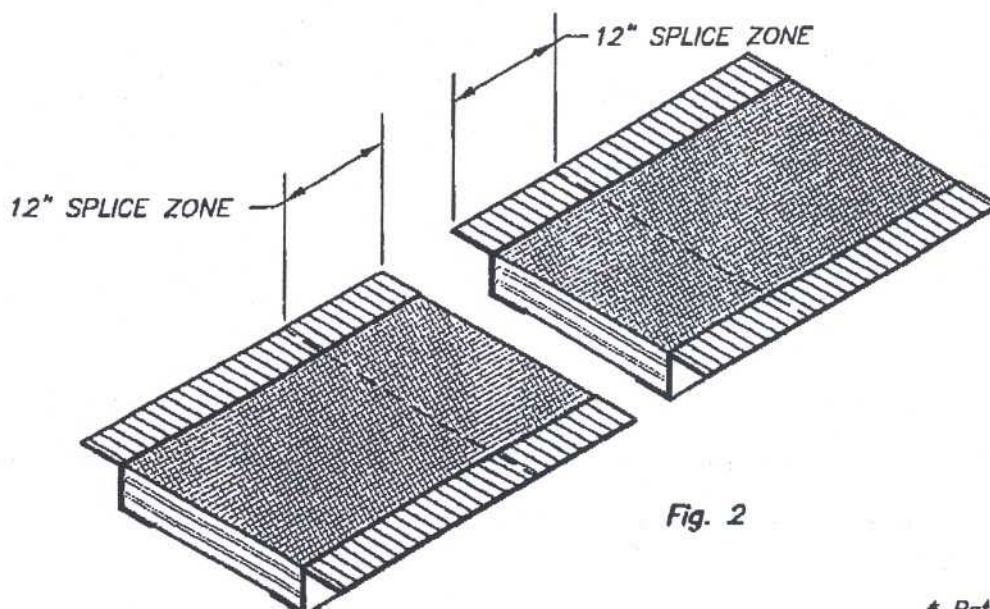

Fig. 2

Splicing Instructions:

Step 2

Make a "tongue and groove" type splice by cutting away every other layer of insulation in the splice zone on each blanket segment and save the scraps for future use. Make the opposite cuts on the other half of the splice. Trim the metallic septum layers the same length as the insulation adjacent to them. (See Figs. 3 & 4)

Note: If flanges are pre-welded to the blanket segments, the flanges must be cut back in one of the splice zones. Overlapping galvanized flanges are not allowed.

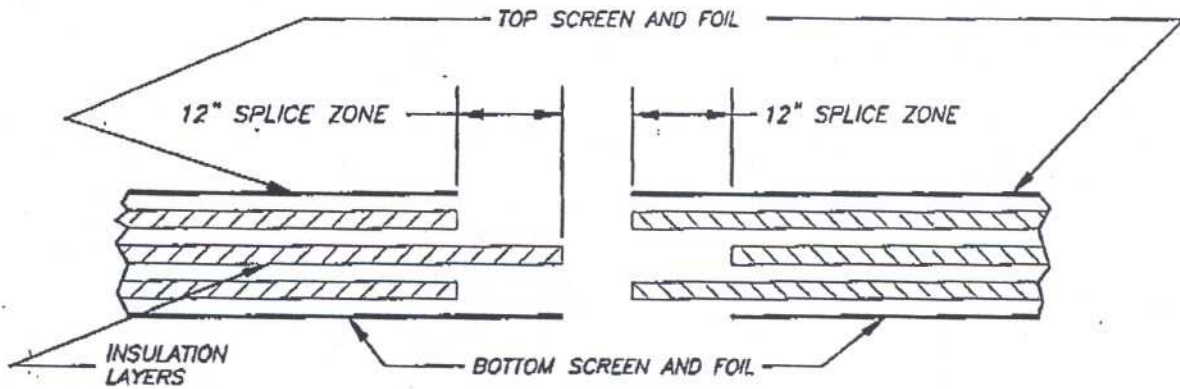

Fig. 3 Cross-Section of Splice Zone

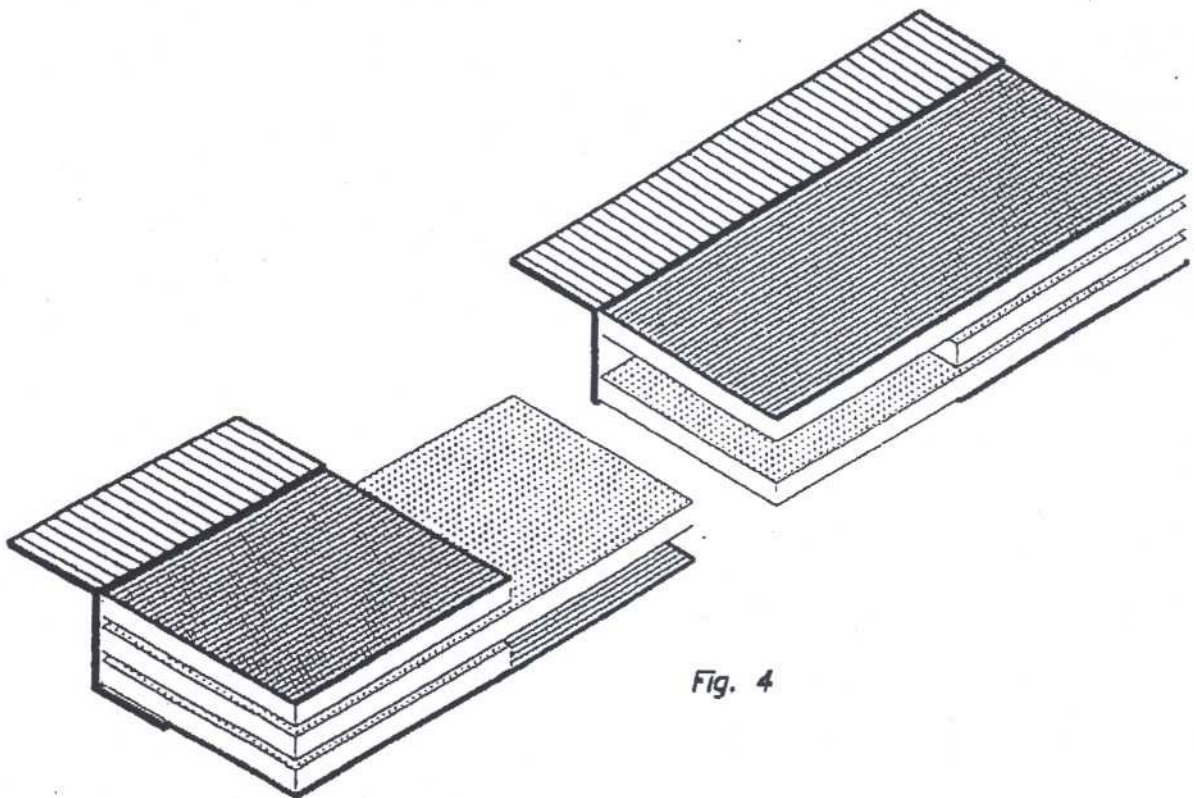

Fig. 4

Splicing Instructions:

Step 3

Assemble the two blanket segments, interweaving the insulation layers.
(See Figs. 5 & 6)

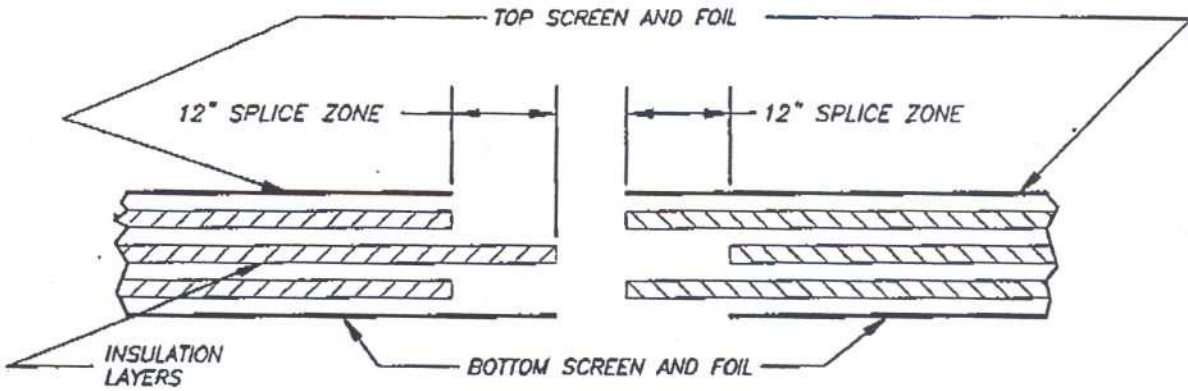
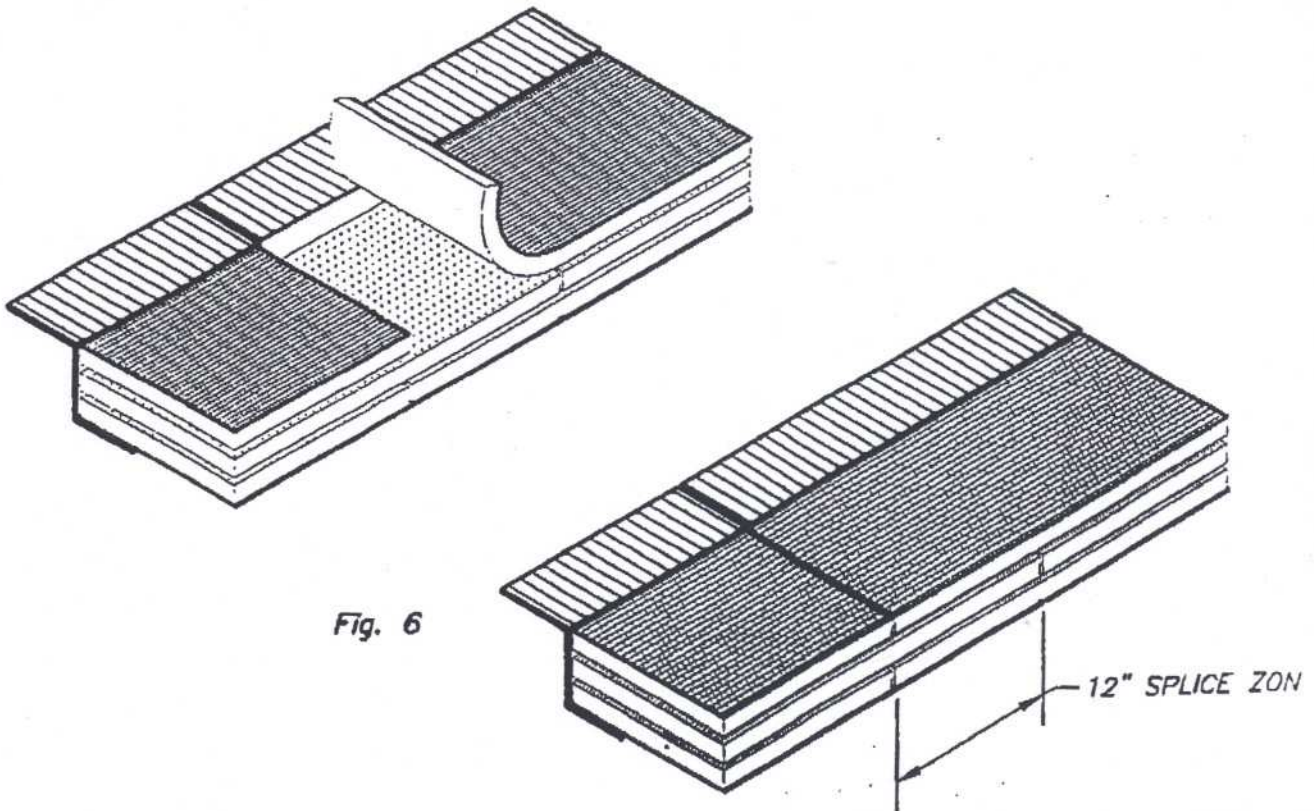

Fig. 5 Cross-Section of Splice Zone



Splicing instructions:

Step 4

Pin the four corners of the splice zone together, through the insulation and the foils, but not through the outer screen layers. (See Figs. 7 & 8)

Place 6 equally spaced pins down the center of the splice zone, through the insulation, through all foil layers and both of the outer screen layers.

(See Figs. 7 & 9)

Inspect the splice to ensure:

a. The splice does not have any gaps.

b. The splice is tied together with pins, down the center line, through the screen.

c. The four corner pins of the splice do not go through the screen.

After the splice has passed inspection, lay the scraps over the splice. These scraps were saved for future use during the completion of Step 2 and should now be laid in over the splice for added thermal protection.

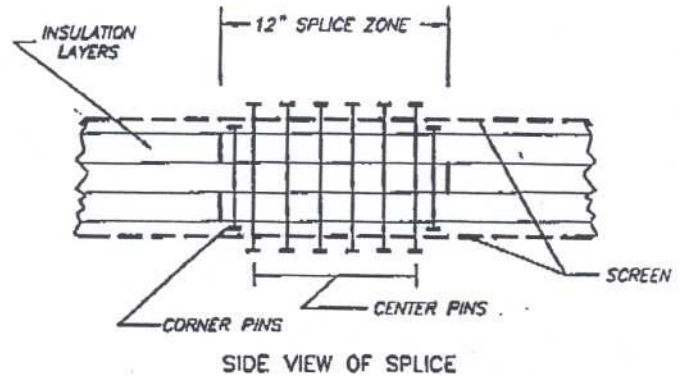
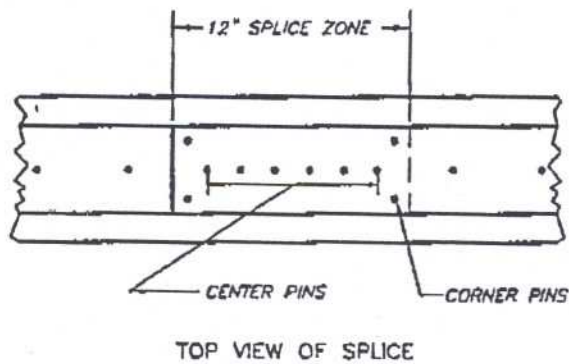

Fig. 7 Assembly of the Splice.

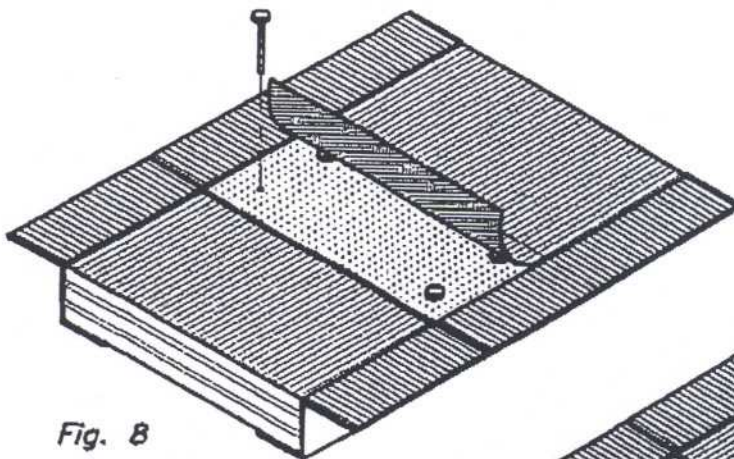

Fig. 8

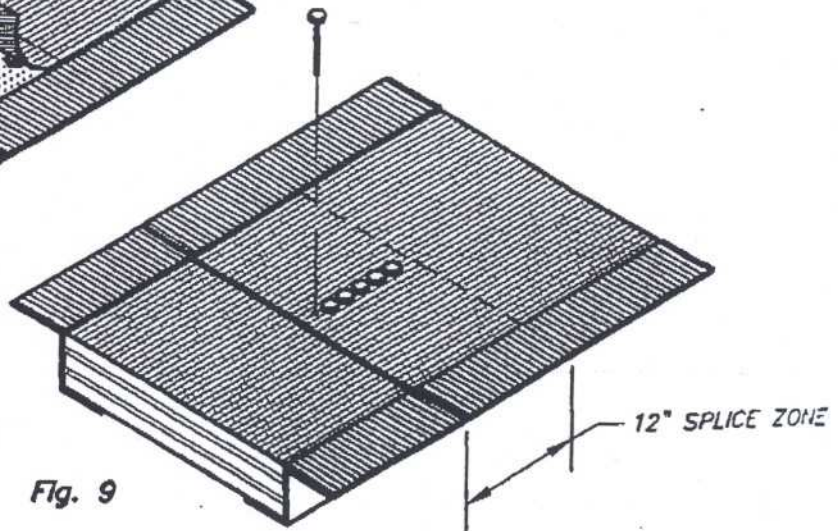
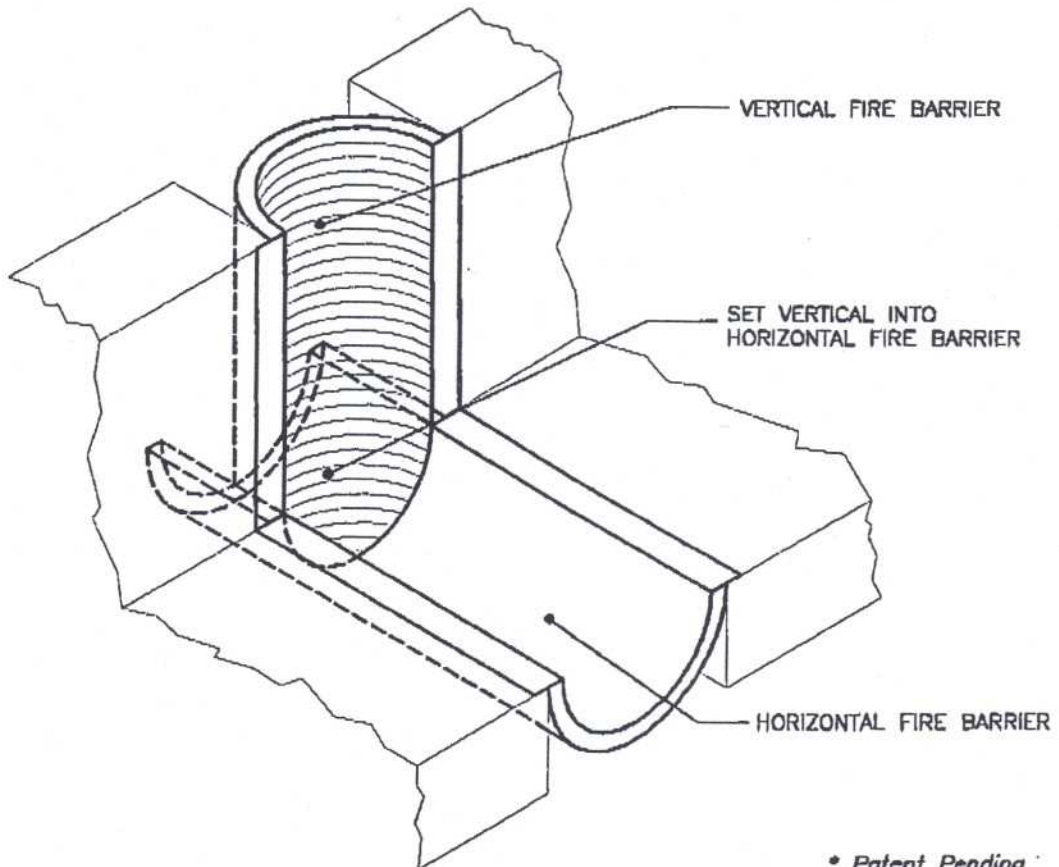
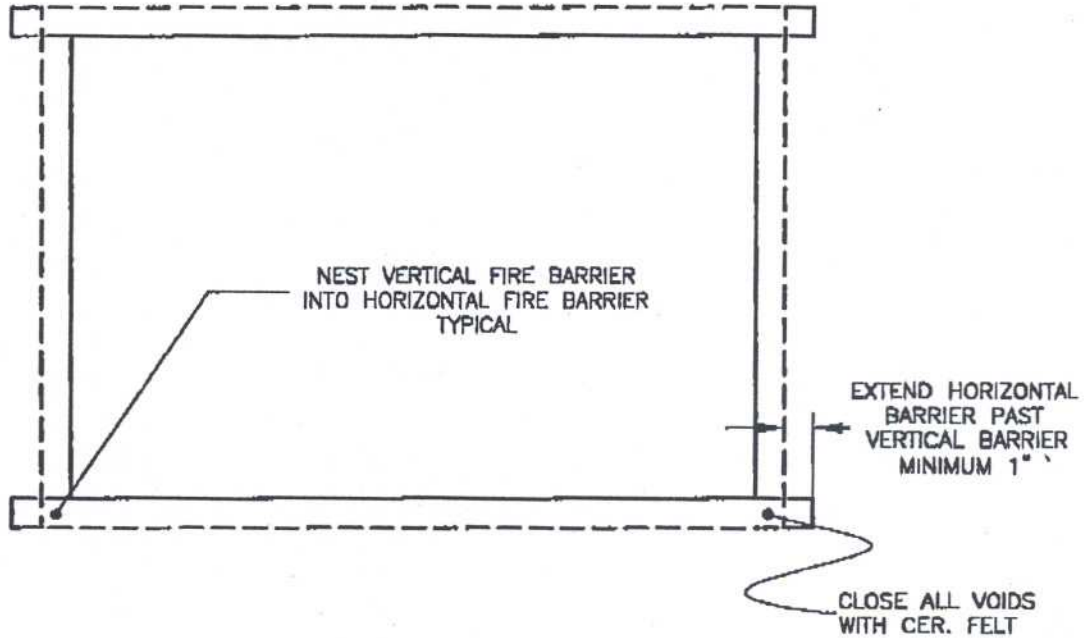

Fig. 9

JM **Johns Manville**
51 Lexington Street
Lewiston, ME 04240-3513
800-445-1500 USA & Canada
207-784-0125 Fax

FS 5800
EXPANSION JOINT -EJ- FIRE BARRIER*
Corridor Wrap Splicing Detail



* Patent Pending

FIRE BARRIER 90° INTERSECTION SPLICE INSTALLATION INSTRUCTIONS

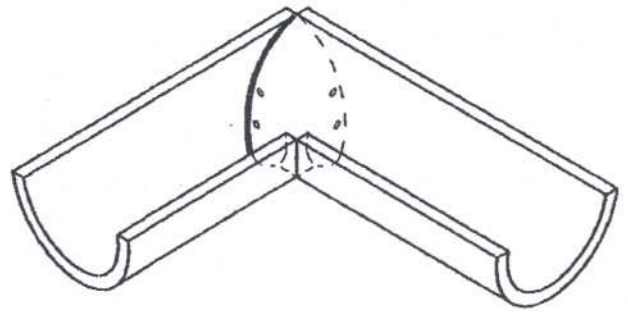

ISOMETRIC VIEW

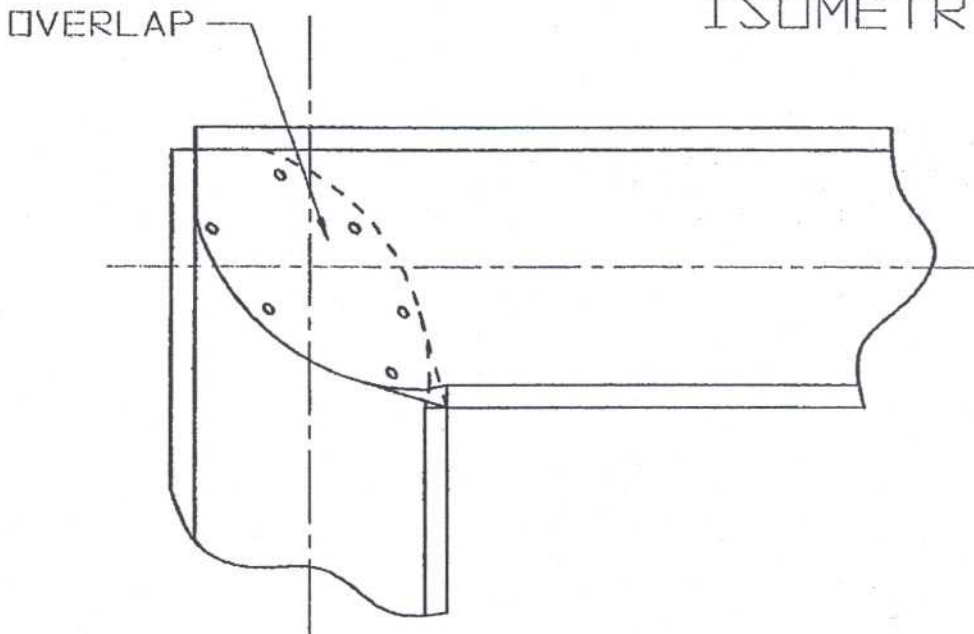

PLAN VIEW

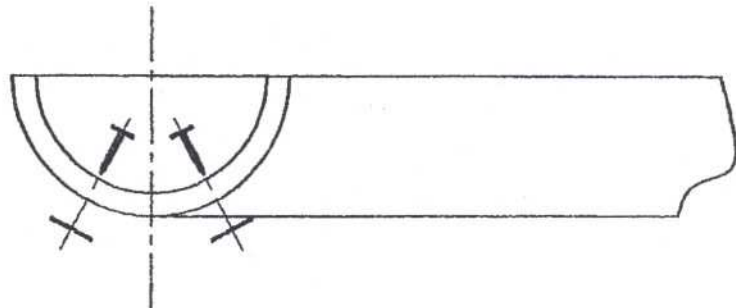

ELEVATION